

NC1V Circuit Breakers

Key features:

- Superior protection for a wide range of devices from sensitive electronic equipment to electrical control circuits. Applications include semi-conductor manufacturing equipment, electronic controllers, computers, microprocessors, communications equipment, power supplies, machine tools, motors, and more.
- Excellent tripping time curve performance
- Flat retractable lever for safety operations
- Slim housing design
- Spring-up terminals allow for use of ring terminals
- Fingersafe main circuit terminals
- Color (red/green) contact position indicator
- DIN rail or direct panel mounting (through-panel mounting brackets available)
- Optional built-in auxiliary / alarm contacts

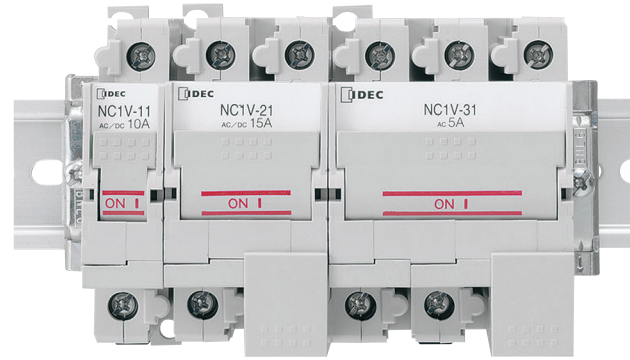

Applicable Standards	Certification Mark	File Number
UL1077		E68029
CSA C22.2 No. 235		LR83454
EN60934		B07 09 13332 063
		European Commission's Low Voltage Directive
GB17701-1999		No. 2008010307265840
Electrical Appliance and Material Safety Law Technical Standard	Series Trip	
	Relay Trip	

Part Number Structure

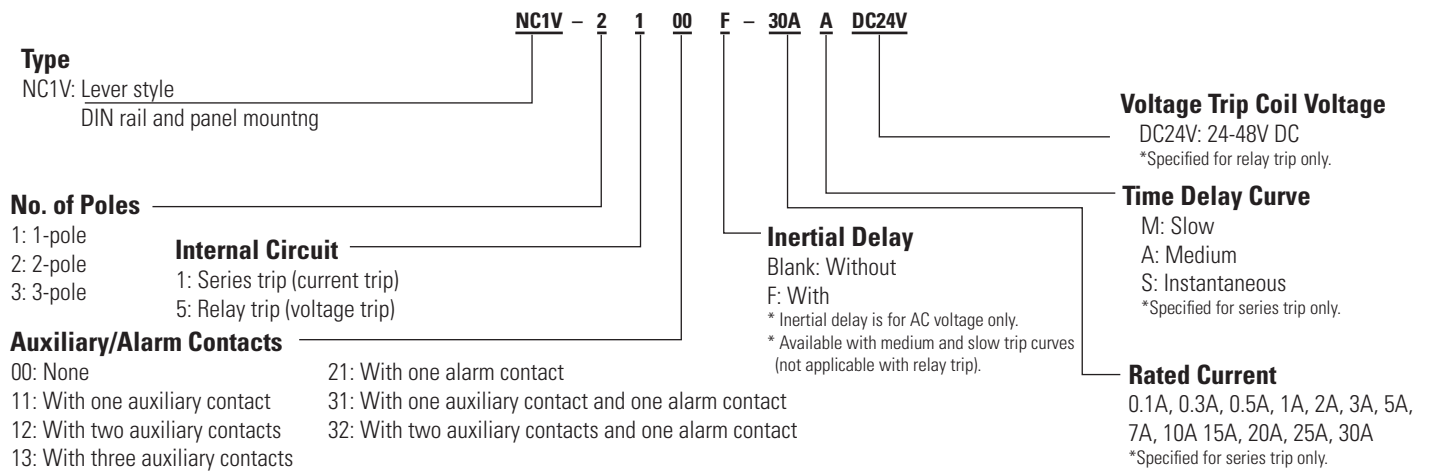

Switches & Pilot Lights
 Signaling Lights
 Relays & Sockets
 Timers
 Contactors
 Terminal Blocks

Circuit Breakers

Specifications

Switches & Pilot Lights

Signaling Lights

Relays & Sockets

Timers

Contactors

Terminal Blocks

Circuit Breakers

Internal Circuit		Series trip (current trip), Relay trip (voltage trip)		
Protection Method		Hydraulic magnetic tripping system, Magnetic tripping system (voltage trip)		
No. of Poles		1-pole	2-pole	3-pole
Rated Voltage (AC/DC) ¹		250V AC 50/60Hz, 65V DC	250V AC 50/60Hz, 125V DC	250V AC, 50/60Hz
Series Trip (Current Trip)	Rated Short-circuit Capacity	250V AC, 2500A 65V DC, 2500A	250V AC, 2500A 125V DC, 2500A	250V AC, 2500A
	Rated Current	0.1A, 0.3A, 0.5A, 1A, 2A, 3A, 5A, 7A, 10A, 15A, 20A, 25A, 30A		
	Operation Characteristics ²	Time delay curve curve M (slow), curve A (medium), S (instantaneous) Only curves M and A are also available with inertial delay option.		
Relay Trip (Voltage Trip) ³	Rated Current	30A		
	Trip Voltage	24 to 48V DC (at 25°C) Voltage application duration 10 sec maximum, tripping time 0.1 sec maximum (at rated voltage)		
Auxiliary Contact/Alarm Contact	Contact Rating	125V AC 3A (resistive load), 30V DC 2A (resistive load)		
	Minimum Applicable Load	24V DC 1mA (resistive load, reference value)		
Insulation Resistance		100MΩ minimum (500V DC megger)		
Dielectric Strength		2,000V AC, 1 minute (between terminals when main contacts are open, between live parts of different poles, between live and dead parts) 600V AC (between terminals when auxiliary circuits are open)		
Vibration Resistance (with rated current applied)		Damage limits:	147 m/s ² (10 to 55 Hz) (1-pole, 2-pole), 78 m/s ² (3-pole)	
		Operating extremes:	98 m/s ² (1-pole, 2-pole), 78 m/s ² (3-pole)	
Shock Resistance (S time delay curve: 80% rated current, A, M time delay curve: 100% rated current)		Damage limits:	490 m/s ² (1-pole, 2-pole), 297 m/s ² (3-pole)	
		Operating extremes:	196 m/s ² (S, A, M curves)	
Electrical Life		10,000 cycles minimum (at rated current), 10 operations per minute		
Reference Temperature		40°C		
Operating Temperature		-10 to +60°C (no freezing) Rated current is based on an ambient temperature of 40°C. When the operating temperature exceeds 40°C, derate the rated current by using the factors shown below.		
Operating Humidity		45 ~ 85% RH (no condensation)		
Terminal Style	Main Circuit Terminal	Spring-up, fingersafe terminal: M4 screw (up to 20A), M5 screw (25A and 30A)		
	Auxiliary/Alarm Contacts, Voltage Coil Terminal	M3.5 screw		
Weight (approx.)		1-pole: 90g, 2-pole: 170g, 3-pole: 260g		



¹3-pole model is for AC voltage only.
²For S (instantaneous) tripping curve, a humming sound may occur when used in an AC sinusoidal-wave current circuit around 80% of the rated current, however, the performance of the circuit breaker will not be affected.
 To avoid unnecessary tripping, do not use in circuits where inrush currents may be present.
³Relay trip (voltage trip) type is not equipped with an overcurrent trip function.
 Do not use the NC1V circuit breakers in environments where they are exposed to extreme temperature, humidity, dust, corrosive gases, vibration, shock, or in a circuit where inrush current may be present, otherwise unnecessary operation and damage may occur.

Operating Temp.	Derating Factor
50°C	0.9
55°C	0.8
60°C	0.7

Models

Specify rated current, time delay curve, or voltage trip coil voltage in place of [6] [7] [8] when ordering.

Internal Circuit	No. of Poles	Inertial Delay	Auxiliary Contact Alarm Contact	Part No	Code			
					[6] Rated Current	[7] Time Delay Curve	[8] Voltage Trip Coil Voltage	
Series Trip (Current Trip)	1-pole	—	—	NC1V-1100-[6] [7]	0.1A 0.3A 0.5A 1A 2A 3A 5A 7A 10A 15A 20A 25A 30A	M (slow) A (medium) S (instantaneous)	—	
			One Auxiliary Contact	NC1V-1111-[6] [7]				
			One Alarm Contact	NC1V-1121-[6] [7]				
		With	—	NC1V-1100F-[6] [7]				
			One Auxiliary Contact	NC1V-1111F-[6] [7]				
			One Alarm Contact	NC1V-1121F-[6] [7]				
	2-pole	—	—	NC1V-2100-[6] [7]				
			One Auxiliary Contact	NC1V-2111-[6] [7]				
			Two Auxiliary Contacts	NC1V-2112-[6] [7]				
			One Alarm Contact	NC1V-2121-[6] [7]				
			One Auxiliary Contact and One Alarm Contact	NC1V-2131-[6] [7]				
			With	—				NC1V-2100F-[6] [7]
		One Auxiliary Contact		NC1V-2111F-[6] [7]				
		Two Auxiliary Contacts		NC1V-2112F-[6] [7]				
		One Alarm Contact		NC1V-2121F-[6] [7]				
		One Auxiliary Contact and One Alarm Contact		NC1V-2131F-[6] [7]				
		3-pole		—				—
			One Auxiliary Contact					NC1V-3111-[6] [7]
	Two Auxiliary Contacts		NC1V-3112-[6] [7]					
	Three Auxiliary Contacts		NC1V-3113-[6] [7]					
	One Alarm Contact		NC1V-3121-[6] [7]					
	One Auxiliary Contact and One Alarm Contact		NC1V-3131-[6] [7]					
	With		—	NC1V-3100F-[6] [7]				
			One Auxiliary Contact	NC1V-3111F-[6] [7]				
Two Auxiliary Contacts			NC1V-3112F-[6] [7]					
Three Auxiliary Contacts			NC1V-3113F-[6] [7]					
One Alarm Contact			NC1V-3121F-[6] [7]					
One Auxiliary Contact and One Alarm Contact			NC1V-3131F-[6] [7]					
Two Auxiliary Contacts and One Alarm Contact	—	NC1V-3132F-[6] [7]						
	—	NC1V-3100F-[6] [7]						
	—	NC1V-3111F-[6] [7]						
	—	NC1V-3112F-[6] [7]						
	—	NC1V-3113F-[6] [7]						
	—	NC1V-3121F-[6] [7]						
Relay Trip (Voltage Trip)	1-pole	—	—	NC1V-1500-[8]	—	—	DC24V	
	2-pole			NC1V-2500-[8]				
	3-pole			NC1V-3500-[8]				

Switches & Pilot Lights

Signaling Lights

Relays & Sockets

Timers

Contactors

Terminal Blocks

Circuit Breakers

Internal Circuits

1-pole

NC1V-1100
(Without auxiliary/alarm contacts)



NC1V-1111
(With auxiliary contact)

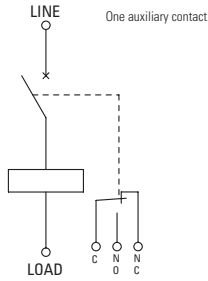

NC1V-1121
(With alarm contact)

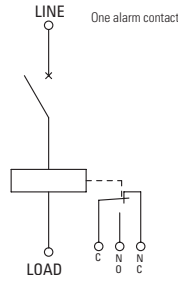

NC1V-1500
(Relay Trip)

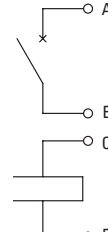

2-pole

NC1V-2100
(Without auxiliary/alarm contacts)

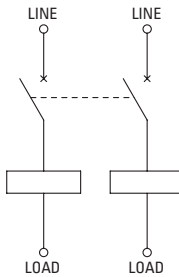

NC1V-2111
(With auxiliary contact)

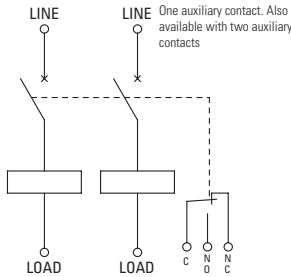

NC1V-2121
(With alarm contact)

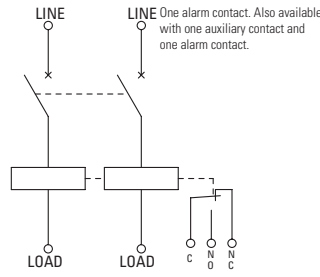

NC1V-2500
(Relay Trip)

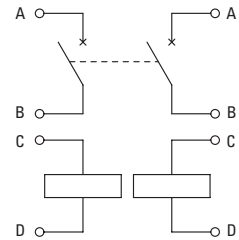

3-pole

NC1V-3100
(Without auxiliary/alarm contacts)

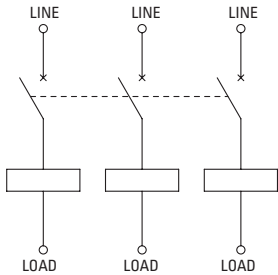

NC1V-3111
(With auxiliary contact)

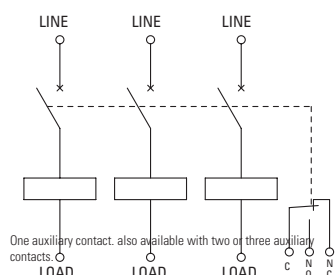

NC1V-3121
(With alarm contact)

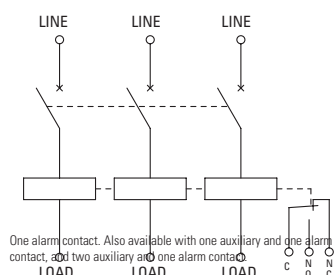

NC1V-3500
(Relay Trip)

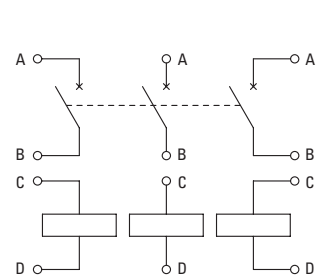

Overcurrent-Time Delay Characteristics (seconds @ 40 deg C) [vertical mounting]

Item	Time Delay Curve	Percent of Rated Current								
		100%	125%	150%	175%	200%	400%	600%	800%	1000%
AC (50/60Hz)/DC	S (instantaneous)	NO TRIP	—	*0.005 to 0.1	0.003 to 0.06	0.0027 to 0.05	0.002 to 0.03	0.002 to 0.028	0.002 to 0.025	0.002 to 0.022
	A (medium)	NO TRIP	*25 to 240	16 to 140	—	6 to 32	0.4 to 4	0.0055 to 1.5	0.004 to 0.8	0.004 to 0.65
	M (slow)	NO TRIP	*60 to 600	30 to 200	—	9 to 60	0.4 to 10	0.006 to 4.5	0.004 to 1.8	0.004 to 0.8
AC (50/60Hz)	With Inertial Delay A (medium)	NO TRIP	25 to 240	—	—	6 to 32	0.8 to 6	0.09 to 3.5	0.02 to 1.8	0.01 to 1.0
	With Inertial Delay M (slow)	NO TRIP	60 to 600	—	—	10 to 60	0.8 to 10	0.06 to 4.5	0.02 to 3	0.01 to 1.75

*: MAY TRIP on DC

Switches & Pilot Lights

Signaling Lights

Relays & Sockets

Timers

Contactors

Terminal Blocks

Circuit Breakers

Time Delay Curves at 40°C

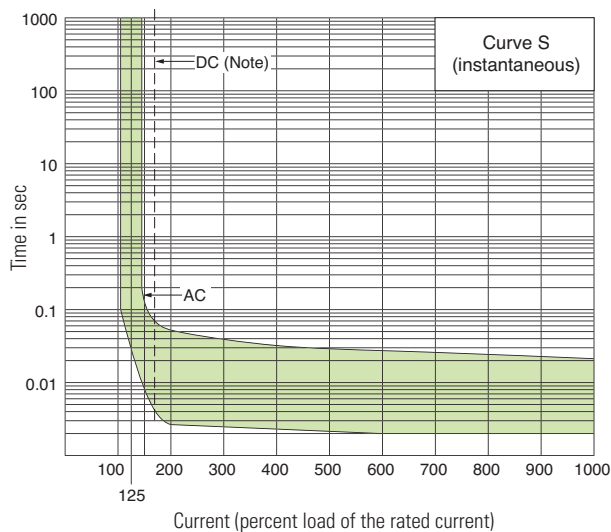
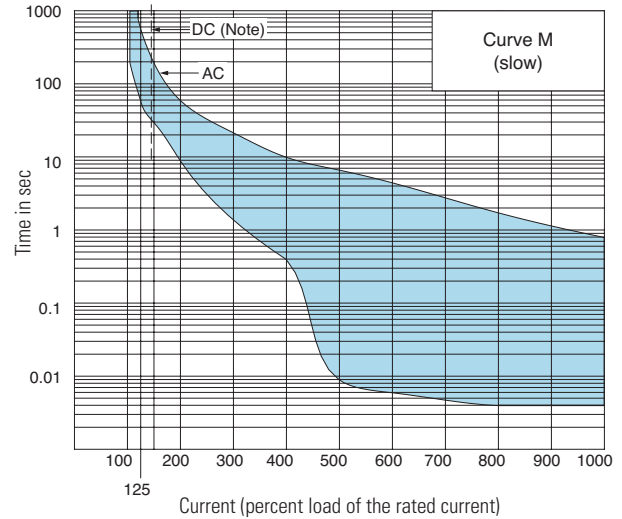
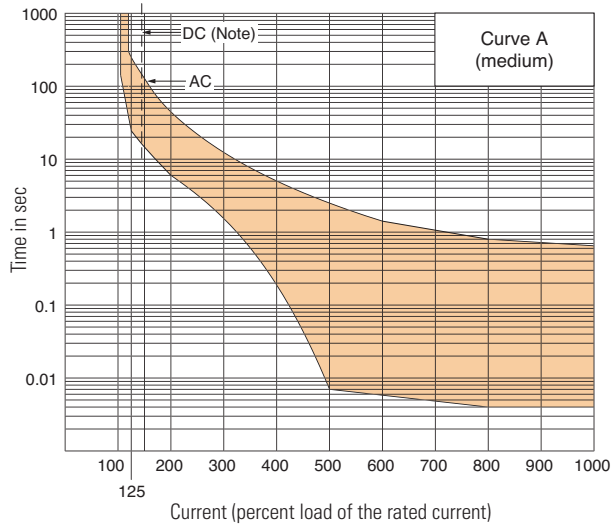

Note: The entire shaded area applies to AC. For DC, the shaded area on the right of the dashed line applies.

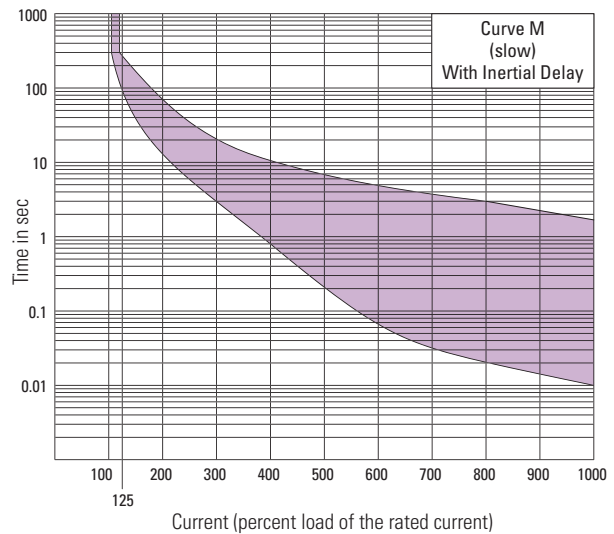
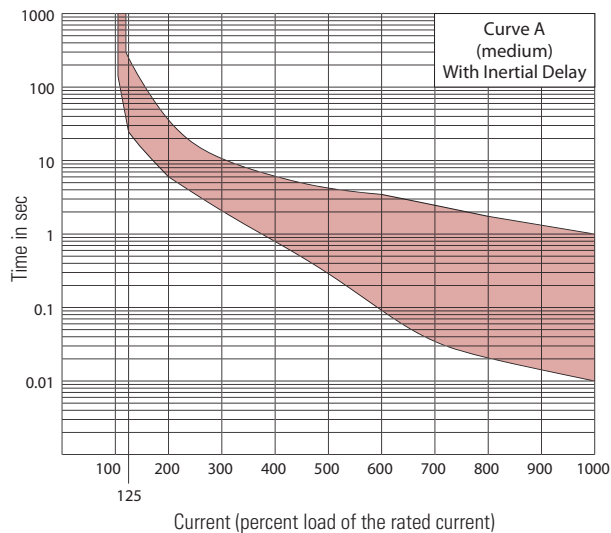

Note: Inertial Delay option not available with S (instantaneous) curve.

Switches & Pilot Lights

Signaling Lights

Relays & Sockets

Timers

Contactors

Terminal Blocks

Circuit Breakers

Time Delay Curve and Ambient Temperature

NC1V circuit breakers employ a hydraulic magnetic tripping system, where the rated current (trip current) is not affected by ambient temperatures. But the time delay may vary with the oil viscosity in the oil dash pot. Lower oil viscosity at higher temperatures results in a shorter delay, whereas at lower temperatures the delay will be longer.

Temperature Correction Curve

The time delay curves on the preceding page are measured at 40°C. With reference to the following curves, time delays can be corrected according to ambient temperature.

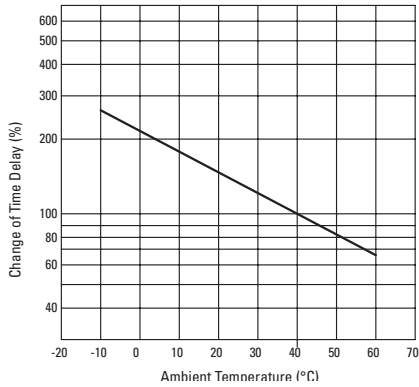

The time delay is based on an ambient temperature of 40°C. Time delays at other temperatures are corrected according to the temperature correction curve. The time delay of the instantaneous time delay curve (S) is not affected by ambient temperature.

When operating temperature exceeds 40°C, derate the rated current by multiplying the derating factor shown on the right.

Operating Temp	Derating Factor
50°C	0.9
55°C	0.8
60°C	0.7

Impedance and Coil Resistance Series Trip (Current Trip) at 25°C

Rated Current	For AC 50/60 Hz Impedance (Ω)		For DC Resistance (Ω)	
	Curve S	Curves A, M	Curve S	Curves A, M
0.1A	66.0	116.0	43.0	106.0
0.3A	6.6	11.0	4.1	10.0
0.5A	1.92	3.65	0.86	3.40
1A	0.50	0.93	0.25	0.90
2A	0.16	0.27	0.11	0.25
3A	0.07	0.12	0.050	0.11
5A	0.025	0.050	0.015	0.045
7A	0.014	0.027	0.011	0.025
10A	0.007	0.021	0.005	0.020
15A	0.006	0.010	0.005	0.009
20A	0.005	0.006	0.004	0.005
25A	0.004	0.005	0.004	0.005
30A	0.003	0.004	0.003	0.004

Tolerance: ±25% (up to 20A), ±50% (25A and 30A)

Relay Trip (Voltage Trip) at 25°C

Tripping Voltage	For DC Resistance (Ω)
24-48V	100.0

Tolerance: ±25%

Inertial Delay

Inertial delay is designed not to trip on a non-repeating single pulse of 20 times the rated current (peak value) for a duration of 8ms. In addition, circuit breakers equipped with inertial delay do not respond to high inrush currents caused by transformer or lamp loads, but perform the specified interruption on subsequent overcurrents. Inertial delay is not available with the series trip curve S (instantaneous).

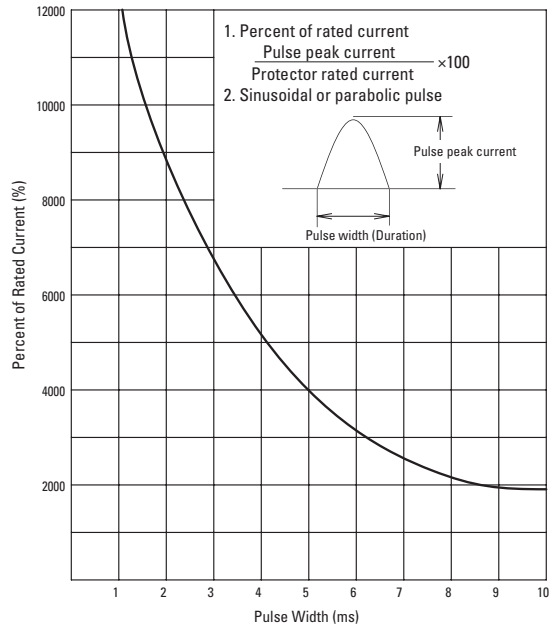

Voltage Drop Due to Coil Resistance or Impedance

The internal resistance or impedance of a circuit breaker tends to be larger for a smaller rated current. Therefore, when circuit breakers with a small rated current are used, voltage drop should be taken into consideration. Internal resistance also varies with time delay curves, which should also be considered during installation.

1-pole

NC1V-1100

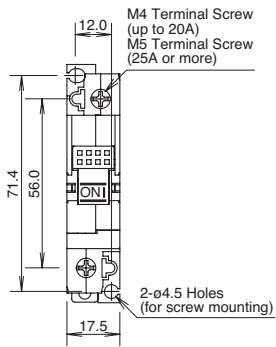

Dimensions (mm)

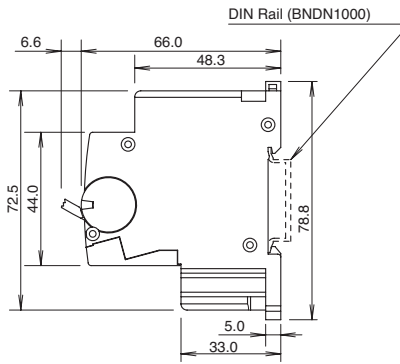

NC1V-1111
(Auxiliary Contact)
NC1V-1121
(Alarm Contact)

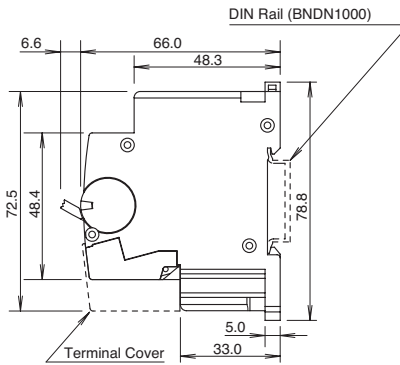
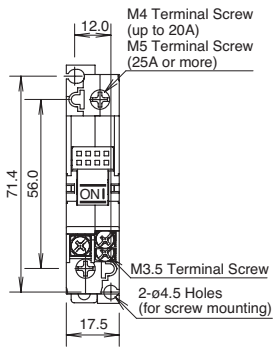

Mounting Hole Layout
(M4 Mounting Screws)

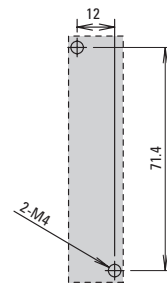

NC1V-1500
(Relay Trip)

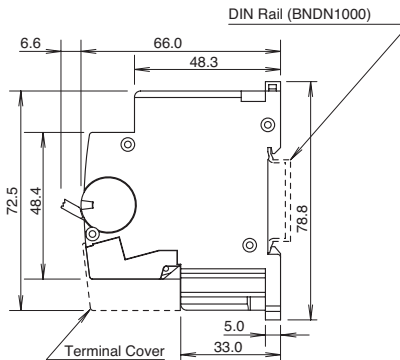
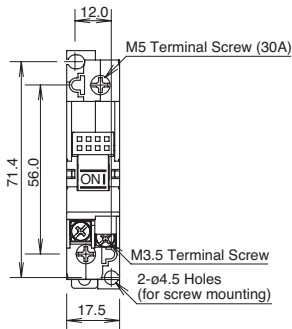

2-pole

NC1V-2100

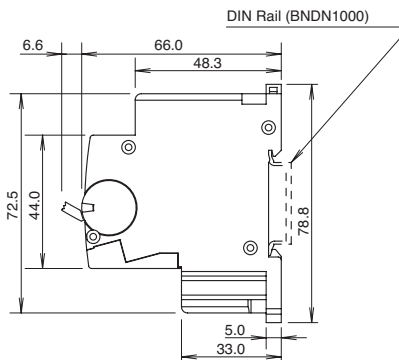
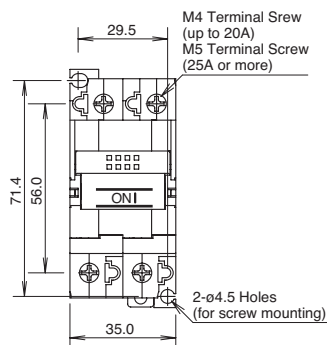

Mounting Hole Layout
(M4 Mounting Screws)

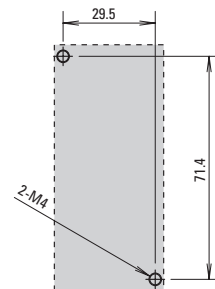

Switches & Pilot Lights

Signaling Lights

Relays & Sockets

Timers

Contactor

Terminal Blocks

Circuit Breakers

Switches & Pilot Lights
 Signaling Lights
 Relays & Sockets
 Timers
 Contactors
 Terminal Blocks
 Circuit Breakers

2-pole

- NC1V-2111
(one auxiliary contact)
- NC1V-2112
(two auxiliary contacts)
- NC1V-2121
(one alarm contact)
- NC1V-2131
(one auxiliary contact and one alarm contact)

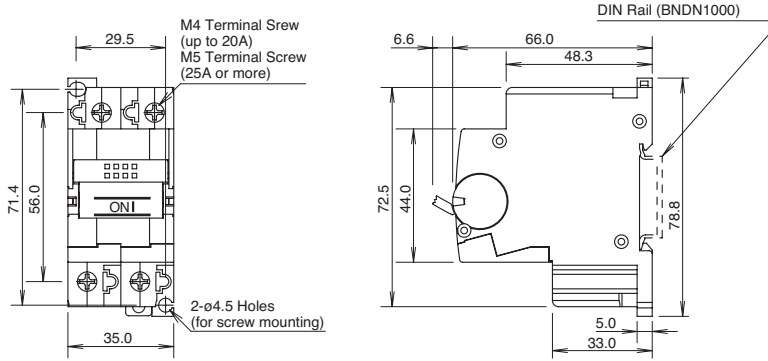

Dimensions shown are for NC1V-2111 and NC1V-2121.

Mounting Hole Layout (M4 Mounting Screws)

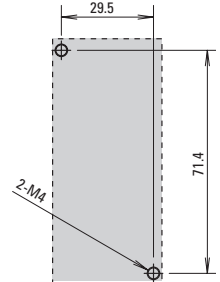

- NC1V-2500
(Relay Trip)

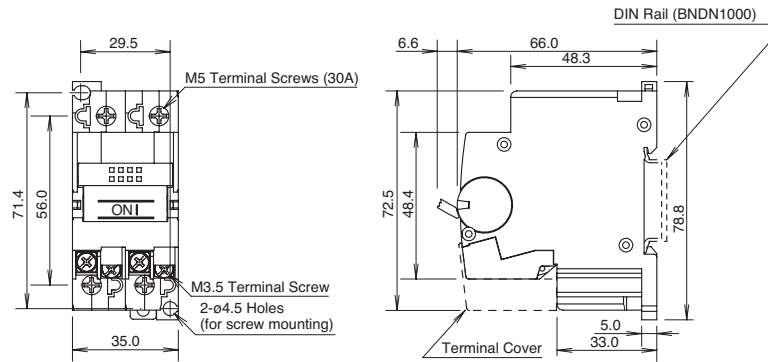

3-pole

- NC1V-3100

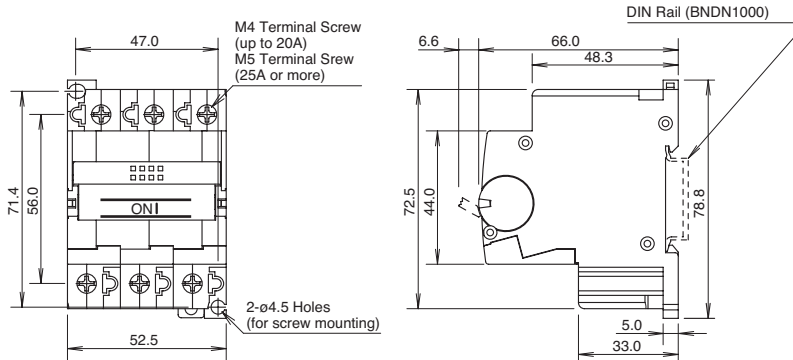

Mounting Hole Layout (M4 Mounting Screws)

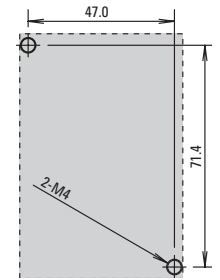

- NC1V-3111
(one auxiliary contact)
- NC1V-3112
(two auxiliary contacts)
- NC1V-3113
(three auxiliary contacts)
- NC1V-3121
(one alarm Contact)
- NC1V-3131
(one auxiliary contact and one alarm contact)
- NC1V-3132
(two auxiliary contacts and one alarm contact)

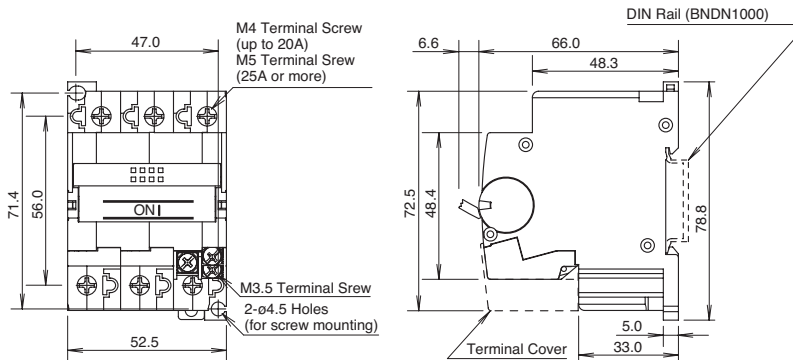

Dimensions shown are for NC1V-3111 and NC1V-3121.

3-pole

NC1V-3500
(Relay Trip)

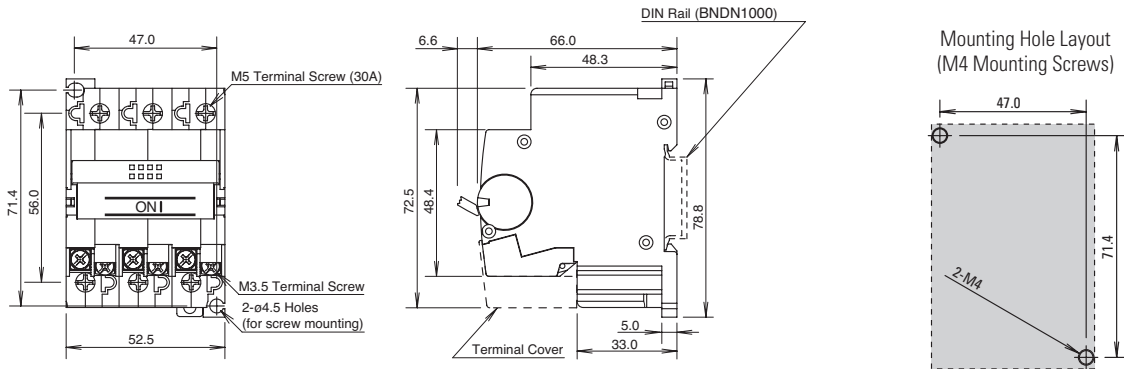

Instructions

Installation Angle

Tripping method is hydraulic magnetic. Minimum operating current varies with installation angle. Operating currents are influenced by the weight of the movable iron core. With reference to the following figures, correct the rated current.

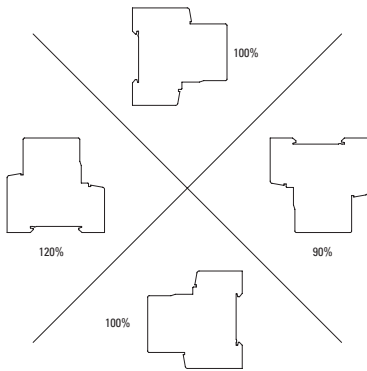

Minimum operating current is calculated from the following formula:
 (Minimum operating current) =
 (Rated current) ×
 (Correction factor by installation angle) × (Reference minimum tripping current rate)

DIN Rails

Installation on DIN Rail

1. Fasten the DIN rail securely.
2. With the latch facing downward, install the NC1V circuit breaker on the DIN rail as shown below.

Removal from DIN Rail

Using a flat screwdriver, pull the latch on the circuit breaker to remove from the DIN rail.

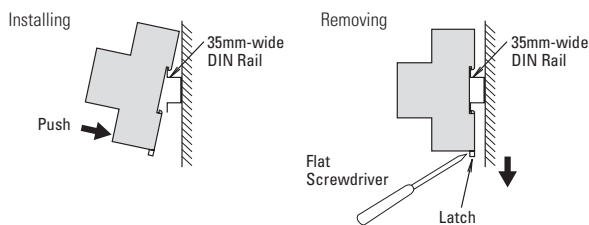

Panel Mounting Screws (not supplied)

Screw Type	Tightening Torque	Shape
M4	0.8 to 1.0 N·m	Spring Washer Plain Washer

Applicable wire and Crimp Terminals

Terminal	Terminal Screw	Connectable Wire Size (mm ²)	Applicable Crimping Terminal	Tightening Torque (N·m)
Main Circuit Terminals	Spring-up, fingersafe, slotted Phillips screw with square washer (up to 20A)	0.25 to 1.65	R1.25-4	1 to 1.4
		1.04 to 2.63	R2-4	
		2.63 to 6.64	R5.5-4	
	Spring-up fingersafe terminal (25A and 30A)	0.25 to 1.65	R1.25-5	1.8 to 2.2
1.04 to 2.63		R2-5		
2.63 to 6.64		R5.5-5		
Auxiliary Contact Alarm Contact Voltage Coil Terminals	Slotted Phillips screw with square washer	0.25 to 1.65	R1.25-3.5	0.7 to 0.9
		1.04 to 2.63	R2-3.5	

- For wiring the main circuit terminal, use applicable crimp terminals and tighten to the recommended torque.
- When using the NC1V circuit breaker as a CSA-certified product, use with CSA-certified crimp terminals.
- When using the NC1V circuit breaker as UL-recognized product, use with UL-recognized crimp terminals.

Product Markings (Example: NC1V-1111-30AA)

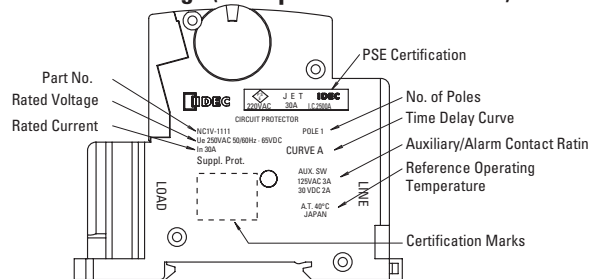

Installation of Auxiliary/Alarm Terminal Cover

After wiring the terminals, install the terminal cover by aligning with the circuit breaker as shown below.

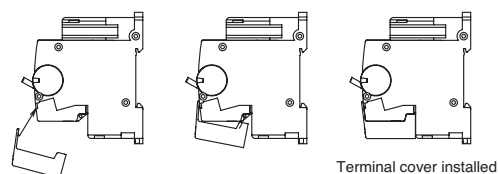

Switches & Pilot Lights

Signaling Lights

Relays & Sockets

Timers

Contactors

Terminal Blocks

Circuit Breakers

Accessories

Switches & Pilot Lights

Signaling Lights

Relays & Sockets

Timers

Contactors

Terminal Blocks

Circuit Breakers

Appearance	Part No.	Description	Appearance	Part No.	Description
	NC9Z-MA11	Panel Cut-Out Mounting bracket for 1-pole model		NC9Z-PW1	Marking Plate Holder*
	NC9Z-MA21	Panel Cut-Out Mounting bracket for 2-pole model		NC9Z-LK1	Padlock attachment**
	NC9Z-MA31	Panel Cut-Out Mounting bracket for 3-pole model		NC1V-AUX-CV	Replacement Auxiliary/ Alarm Terminal Cover (Nylon - PA66)
	NC9Z-TA1	Replacement Wiring Clip when using panel mount brackets	*Marking plate not supplied. ** Padlock not supplied.		