

INSTRUCTION SHEET

HE1B Basic Three-Position Enabling Switches



Confirm that the delivered product is what you have ordered.

Read this instruction sheet to make sure of correct operation. Make sure that the instruction sheet is kept by the end user.

SAFETY NOTE

In this operation instruction sheet, safety precautions are categorized in order of importance to Warning and Caution :

WARNING

Warning notices are used to emphasize that improper operation may cause severe personal injury or death.

CAUTION

Caution notices are used where inattention might cause personal injury or damage to equipment.

1 Type

HE1B-M1N	
Contact Configuration	Mounting style
3-position Switch :1 poles	blank :Side mounting N :Top mounting

2 Specifications and Ratings

Applicable Standards	IEC60947-5-1, EN60947-5-1, JIS C8201-5-1 IEC60947-5-8, EN60947-5-8, UL508, CSA C22.2 No.14				
Standards for Use	ISO12100-1,-2/EN12100-1,-2, IEC60204-1/EN60204-1 ISO11161/prEN11161, ISO10218/EN775 ANSI/RIA R15.06, ANSI B11.19				
Operating Condition	Operating Temperature	-25 to +60°C (no freezing)			
	Operating Humidity	45 to 85%RH (no condensation)			
	Storage Temperature	-40 to +80°C (no freezing)			
	Pollution Degree	2			
Rated Insulation Voltage	250V				
Thermal Current <Ith>	5A				
Contact Ratings (Reference Values) < Ue , Ie >	AC	Resistive load(AC-12)	30V	125V	250V
		Inductive load(AC-15)	-	3A	1.5A
	DC	Resistive load(DC-12)	2A	0.4A	0.2A
		Inductive load(DC-13)	1A	0.22A	0.1A
Impulse Withstand Voltage (Uimp)	2.5kV				
Operation Frequency	1200 operations/hour				
Vibration Resistance	Operating Extremes: 150m/s ²				
	Damage Limits: 500m/s ²				
Shock Resistance	Operating Extremes: 5 to 55 Hz, half amplitude 0.5 mm				
	Damage Limits: 16.7 Hz, half amplitude 1.5 mm				
Degree of Protection	IP40(except terminals)				
Direct Opening Force	30 N minimum(Position2→3)				
Direct Opening Travel	4.1 N minimum				
Conditional short-circuit Current	50A(250V)				
Short-Circuit Protective Device	250V AC, 10A Fuse (IEC60127-1)				
Actuator Strength	250 N minimum				
Weight	Approx. 6g				

3 Notes for Operation

- The enabling switch permits machine operation only while the enabling switch is manually operated for robot teaching or other purposes in hazardous areas. Make sure that the control system is designed to activate the machine only when the enabling switch is at position 2 (2.2mm operating travel).
- To prevent button malfunction, provision for protection is required.

CAUTION

- This product has been designed for environment A.
- Use of this product in B environment may cause unwanted electromagnetic disturbances in which case the user may be required to take adequate mitigation measures. (clause 5, 3 of IEC60947-1)
- Turn off the power to the safety switch before starting installation, removal, wiring, maintenance, and inspection on the safety switch. Failure to turn power off may cause electrical shocks or fire hazard.
- Use wires of proper size to meet voltage and current requirements. Using improper wires may cause fire hazard due to abnormal heat generation.
- Do not apply an excessive shock to the switch.
- Wire the switch correctly after reading a catalog or this instruction sheet.

WARNING

- When using the HE1B for safety-related equipment in a control system, refer to the safety standards and regulations in each country and region depending on the application purpose of the actual machines and installations to make sure of correct operation. Also, perform risk assessment to make sure of safety before starting operation.
- Do not tie the enabling switch around the button with a tape or string, to keep the switch in position 2. Otherwise the original function of the enabling switch is lost, posing a great risk of danger.
- Perform a sufficient risk assessment against the high operating force at transition to the OFF position when the button is pressed to the bottom.
- Perform a sufficient risk assessment against the shape and structure where the enabling switch is mounted, in order to prevent unintended actuation. For example, protrusion from a teaching pendant may cause the enabling switch to be actuated by the weight of the teaching pendant.
- When mounting the HE1B, make sure of sufficient strength of the mounting panel against the anticipated operating physical force. (High operating physical force is expected especially at transition to the OFF position when the button is pressed to the bottom.)
- Strength of the HE1B operator is 250N. If the operating force over 250N is expected, use an actuator with a stopper for the switch operation.

4 Wiring

- Operating Characteristics (Reference Value) : ON (Close) : OFF (Open)

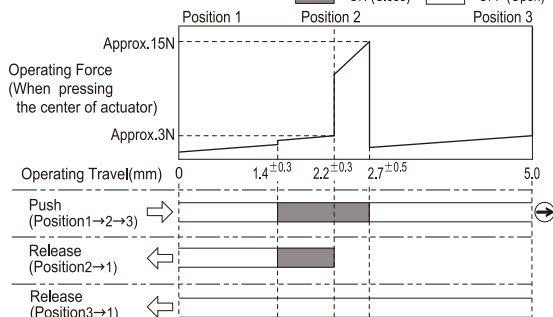

- Configuration of Contacts and Number of Poles

- 3-position Switch: 1 contact

- Applicable Wire Size

- 0.5 mm² (maximum) x 1 pc.

- Terminal Soldering

- Solder the terminal at a temperature of 310 to 350°C within 3 seconds using a soldering iron. Sn-Ag-Cu type is recommended when using lead-free solder.
- When soldering, take care not to touch the enabling switch with the soldering iron. Also ensure that no tensile force is applied to the terminal. Do not bend the terminal or apply excessive force to the terminal.
- Use non-corrosive liquid rosin as soldering flux.

5 Mounting

- Mounting Hole Layout

- HE1B-M1

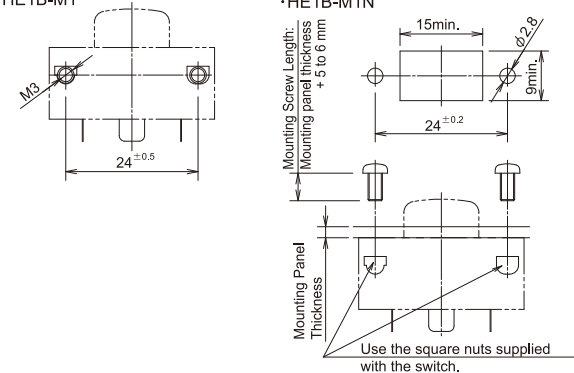

Note: When installed on a mounting panel is thicker than 2mm, the actuator surface is behind the panel when the actuator is pressed to the bottom.(HE1B-M1N)

- Recommended Screw Tightening Torque
M3 screw :0.5 to 0.8N·m (HE1B-M1)
M2.6 screw :0.4 to 0.6N·m (HE1B-M1N)

6 Dimensions

- HE1B-M1※

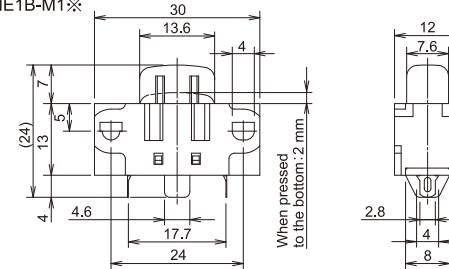

7 Precaution for Disposal

Dispose of HE1B Enabling Switch as an industrial waste.