

Operation Type	: Pushlock
Reset	: Turnreset or Pullreset
□□ (Contact Arrangement)	: 01 (1NC), 02 (2NC), 03 (3NC), 04 (4NC), 11 (1NO-1NC), 12 (1NO-2NC), 13 (1NO-3NC), 22 (2NO-2NC)
* (Button Color)	: R (Red)

Contact Configuration (Bottom View)

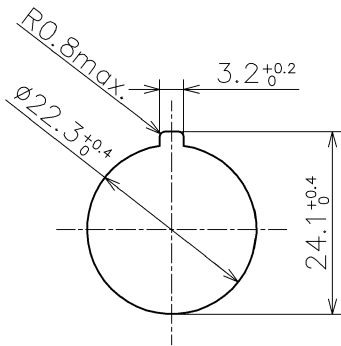

Panel Cut-Out

Monitor contact (1NC contact) included TOP Marking Side

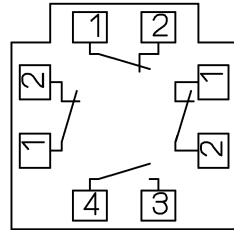

1NC: Terminals on the top.
2NC: Terminals on the right and left.

Monitor contact (2NO contact) included TOP Marking Side

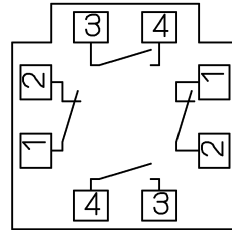

<Contact Configuration> Main contact (NC contact) only. TOP

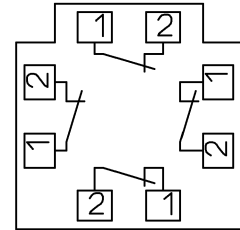

1NC: Terminals on the right.
2NC: Terminals on the right and left.
3NC: Terminals on the right, left and top.

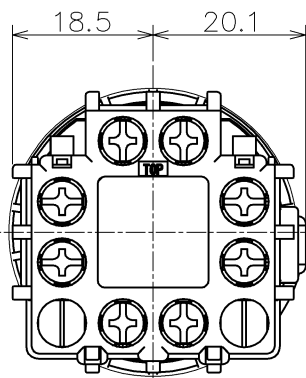
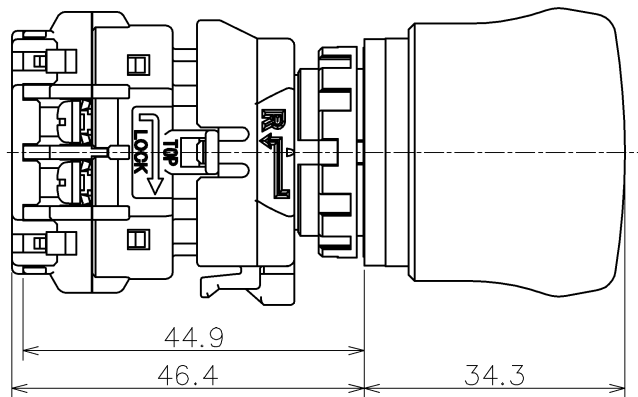

Terminal Cover
XW9Z-VL2M

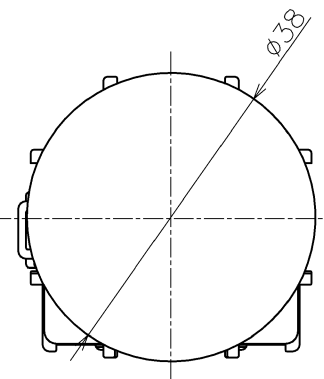
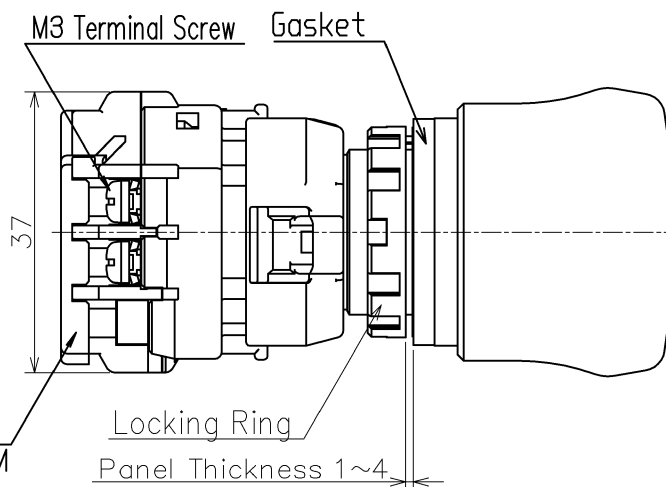

Product Name: XW Series Emergency Stop Switch

Type Number: XW1E-BV4TG□□M*

Approved by	S. Takahashi	Apr. 05, 2016
Checked by	H. Okamura	Apr. 05, 2016
Drawn by	H. Okamura	Apr. 05, 2016

Dim.: mm	Outside View
Drawing No. MA4-A04903	